

NOSTRA
HOMES

Built for living.™

TOWNHOMES

Rosenthal Place



Artist Impression

Discover the charm of contemporary living at Rosenthal Place.

The next-generation of contemporary townhomes at Rosenthal Place aim to redefine the way you can live setting a new benchmark in flexible, light-filled living environments.

As part of this vision, Nostra Homes has partnered with Millet Group to bring you a selection of stunning 2, 3 and 4 bedroom turn-key homes that provide a contemporary living solution for first home buyers, downsizers or those looking for a low maintenance, modern lifestyle.

Featuring an attractive list of fixed price inclusions along with modern and architecturally designed street appeal, these homes are the perfect choice.

“

The Nostra Homes team and I are dedicated and driven to deliver a premium level of service at every step of your journey”



Anthony Caruana
Founder



Turn the page to a life well lived at Rosenthal – where modern convenience meets natural charm.

Rosenthal Place offers the ideal balance of city convenience and country charm — just 35min drive from Melbourne’s CBD and surrounded by Sunbury’s finest parks, vibrant community spaces, and the ideal setting to create lasting memories in a place that truly feels like home.



Neighborhood shopping precincts inclusive of major supermarkets and specialty retailers.



A selection of great primary and secondary schools and childcare.



Extensive parklands, picnic areas and walking & cycling trails.



An abundance of sporting clubs and recreational facilities.



Convenience of two train stations and proximity to major freeway arterials.



NOTE All distances and travel timeframe references are approximate only, refer to distance or travel timeframe by car (unless specified otherwise), and are based on information obtained from Google Maps.

A connected life.

To live at Rosenthal Place is to live a truly connected life. Everything you could want is within easy reach.

With such a great list of nearby amenities along with a functional floorplan and architectural façade, you'll love calling Rosenthal Place home.

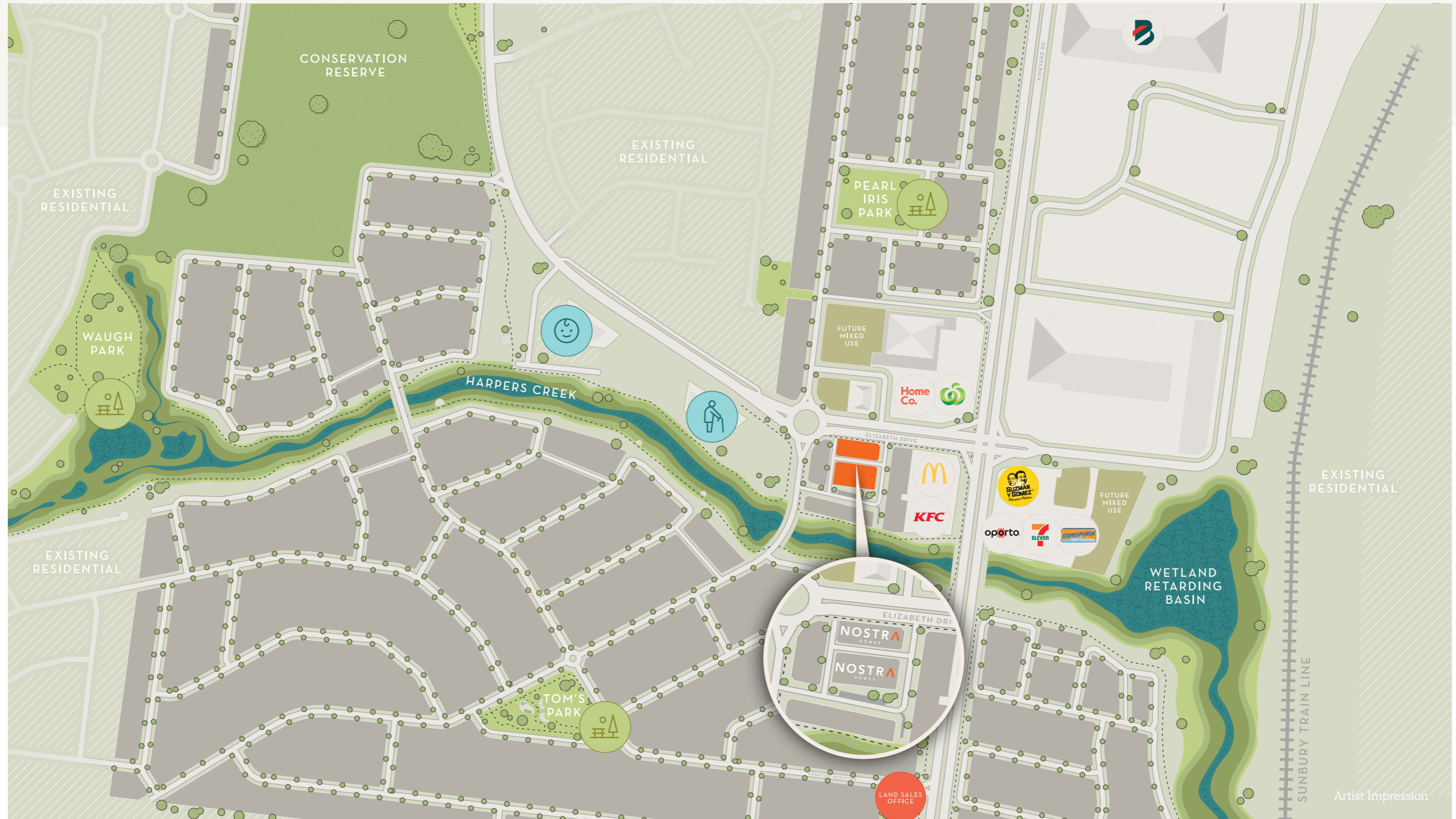

Information and other content contained within this document is believed to be accurate as at August 2025 but may change at any time without notice. The plans used are indicative and subject to change. No warranty can be given regarding the accuracy, adequacy or completeness of any information presented. Conservation reserves are intended for conservation purposes only and are not intended for public access. The photographs and artist impressions are for illustrative purposes only. Purchases must carefully review the information within the contract of sales prior to purchase.

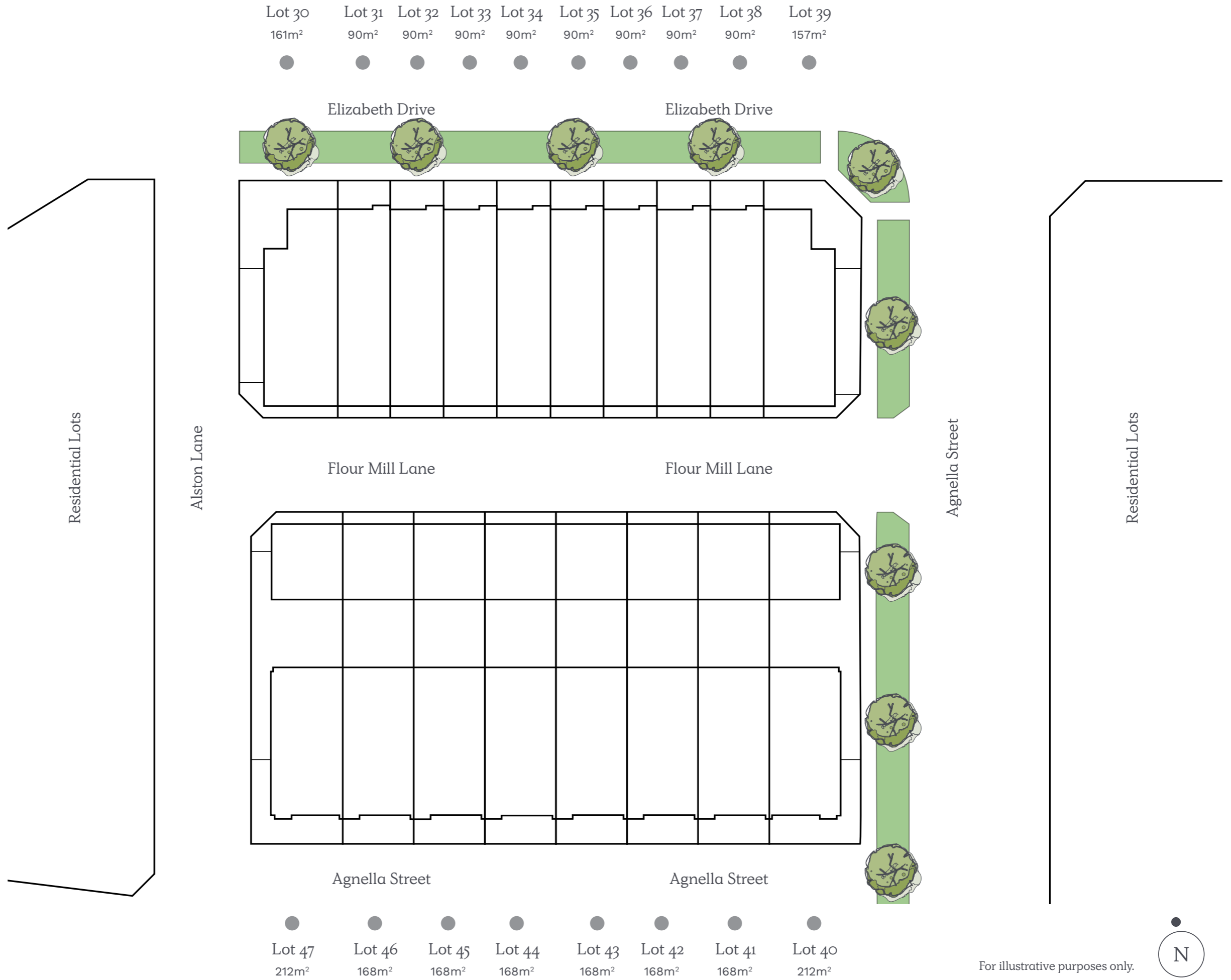

For illustrative purposes only.



Choose your design.



Find the perfect home that aligns with your lifestyle and budget.

Lot 39	Lot 38	Lot 37	Lot 36	Lot 35	Lot 34	Lot 33	Lot 32	Lot 31	Lot 30
19.83sq	16.04sq	16.04sq	16.04sq	16.04sq	16.04sq	16.04sq	16.04sq	16.04sq	19.83sq
4 2 2	2 2 1	2 2 1	2 2 1	2 2 1	2 2 1	2 2 1	2 2 1	2 2 1	4 2 2
<input type="radio"/>	<input type="radio"/>	<input type="radio"/>	<input type="radio"/>	<input type="radio"/>	<input type="radio"/>	<input type="radio"/>	<input type="radio"/>	<input type="radio"/>	<input type="radio"/>



Murano 19cr

Lot 30, 39
House Size 19.83sq

 4
  2
  2



NOTE: Floorplan displayed is for illustrative purposes only.
Refer to contract plans for orientation, facade and final landscaping layout.

Murano 16r

Lot 31, 32, 33, 34, 35, 36, 37, 38
House Size 16.04sq

 2
  2
  1

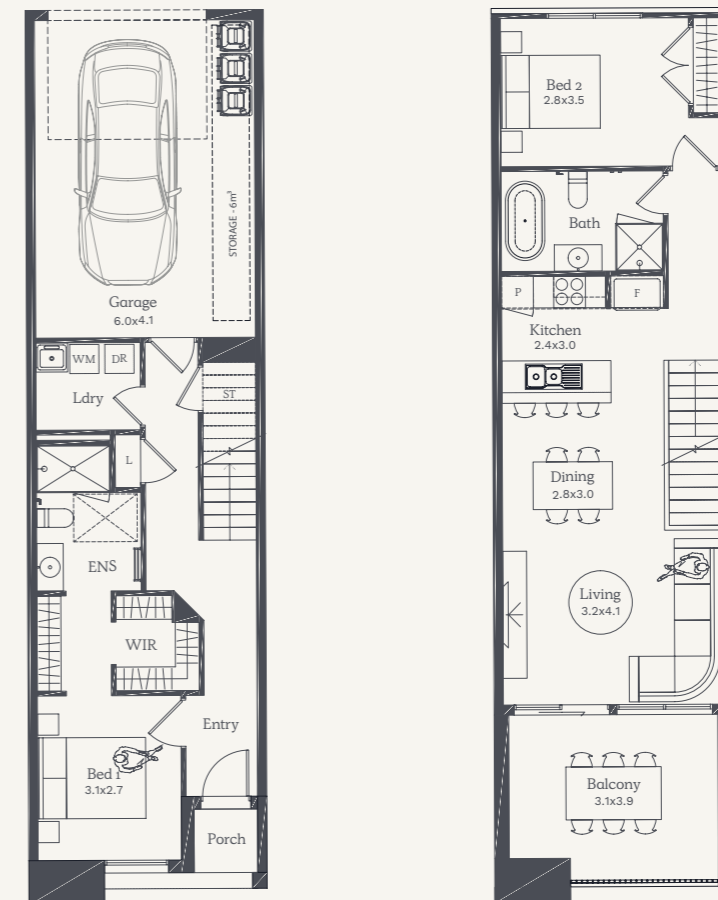

NOTE: Floorplan displayed is for illustrative purposes only.
Refer to contract plans for orientation, facade and final landscaping layout.

Choose your design.



Find the perfect home that aligns with your lifestyle and budget.

Lot 47	Lot 46	Lot 45	Lot 44	Lot 43	Lot 42	Lot 41	Lot 40
19.87sq	19.91sq	19.91sq	19.91sq	19.91sq	19.91sq	19.91sq	19.87sq
3 2 2	3 2 2	3 2 2	3 2 2	3 2 2	3 2 2	3 2 2	3 2 2
<input type="radio"/>	<input type="radio"/>	<input type="radio"/>	<input type="radio"/>	<input type="radio"/>	<input type="radio"/>	<input type="radio"/>	<input type="radio"/>



Lipari 19c

Lot 40, 47
House Size 19.87sq

 3
  2
  2

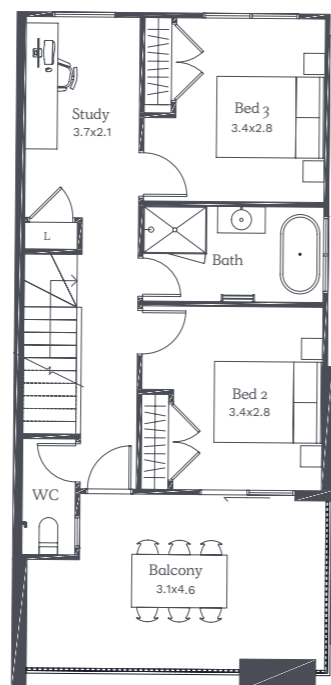
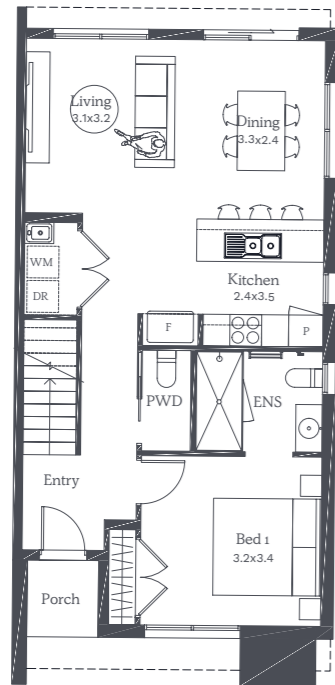
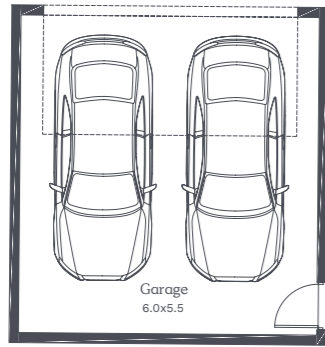

NOTE: Floorplan displayed is for illustrative purposes only.
Refer to contract plans for orientation, facade and final landscaping layout.

Lipari 19

Lot 41, 42, 43, 44, 45, 46
House Size 19.91sq

 3
  2
  2

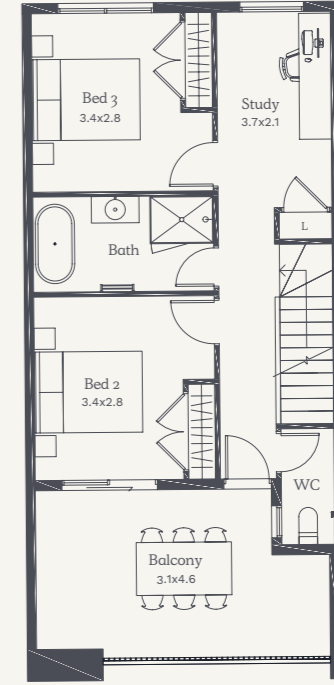
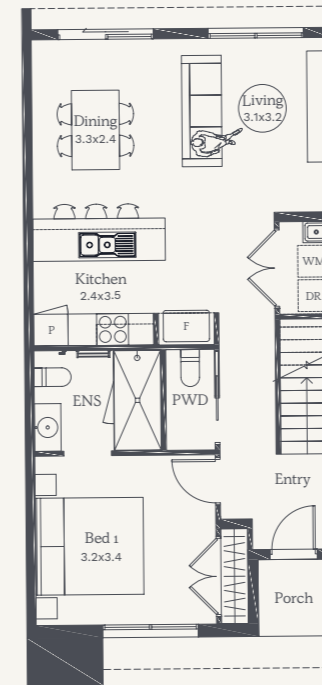
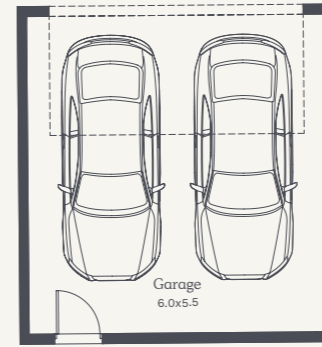

NOTE: Floorplan displayed is for illustrative purposes only.
Refer to contract plans for orientation, facade and final landscaping layout.



General	
Guarantee	25 year structural guarantee
Construction	Dwelling constructed independently

Connections	
Taps	Garden tap
Stormwater	Stormwater drains
Sewer	Sewer drains
Utilities	Electricity and water connections
Fibre Optic	Fibre optic provisions (does not include installation of hub or final connections)
Costs	All connections exclude consumer connection fees and utility account opening fees

Foundations	
Site Costs	Fixed site costs (includes rock and retaining walls) Note: Retaining walls are included for structural requirements only. Any retaining wall requirements for landscaping are not included
Slab	Engineered concrete slab

Framing	
Wall Frames	Stabilised pine or steel wall frames with lintels and beams
Ceiling	Engineered designed roof trusses

Ceilings	
Single Storey	2590mm high ceilings
Double Storey	2590mm high ceilings to main living and 2440mm to other level
Plasterwork	Cove cornice to entire home

Windows	
Material	Aluminium windows
Locks	Keyed locks to all windows

Facade	
Facade	Facade as noted in approved architectural drawings

External Cladding	
Cladding	VBA compliant cladding

Roof	
Roof Materials	Metal sheet roofing or concrete roof tiles (floorplan specific)
	Coloured fascia, gutter, downpipes and cappings

Insulation	
Wrap	Sisalation wall wrap
External Walls	Wall batts to external walls
Ceiling Cavity	Insulation wool to ceiling cavity of living areas

Hot Water System	Electrical storage hot water unit
-------------------------	-----------------------------------

Garage	
Garage Door	Panel lift garage door with 2 hand held and 1 wall mounted remote control

Staircase	
Stairs	MDF treads and risers with carpet (floorplan specific)

Doors / Furniture	
Entry	Solid core door with digital entrance lock
Internal	Flush panel doors with satin chrome passage handles and air cushioned door stops. Ensuite & laundry door is floorplan specific. (refer to contract plans)

Robes	Chrome knob to robe cupboards
--------------	-------------------------------

Skirting / Architraves	
Mouldings	67mm x 18mm primed MDF skirting and architraves
Wet Area	Tiled skirting 100mm to wet areas

Shelving	
Robes	1 x melamine shelf with chrome hanging rails
Linen	3 x melamine shelves
Pantry	4 x melamine shelves

Electrical	
Safety Switches	Safety switches (residual current devices)
Smoke Detector(s)	Direct wired smoke detectors
Internal Light Points	LED downlights to home (as per plan)

External Lights	1 x rear flood light
Exhaust Fans	Exhaust fans to areas with no openable window

Power Points	1 x double powerpoint to each room (refer to electrical plans)
---------------------	----------------------------------------------------------------

TV/Phone Point	1 x television and phone point (refer to electrical plans)
-----------------------	------------------------------------------------------------

Data Point	1 x data point (refer to electrical plans)
-------------------	--------------------------------------------



Lofty high ceilings

LED downlights to home

Overhead cupboards including feature open shelves

20mm kitchen mineral surface benchtop

Timber laminate to main living areas

Artist Impression: Images used are for colour reference and material finish only, please refer to contract drawings. Image shown includes upgrade options. Note: undermount sink, overhead cupboards above fridge and decor are not included. Render based on a Capri Series kitchen design.

Heating / Cooling	
Heating Panels	Heating panels to all bedrooms and second living (floorplan specific)
Cooling System	Reverse cycle split system to main living (unit size is floorplan specific)

Toilets	
Toilet Suite	Dual flush cisterns with vitreous china pan
Toilet Roll	Toilet roll holders
Basin	Wall mounted basin with mirror to powder room (floorplan specific)

Bathroom and Ensuite	
Cabinetry	Laminate cabinets
Benchtops	20mm mineral surface benchtops
Basin/Tapware	Vitreous china designer basins with chrome flick mixers
Bath	Freestanding bath with chrome outlet and tap set (floorplan specific)
Mirror	Polished edge mirrors (size is width of vanities)
Shower Base	Tiled shower base
Shower Screen	Framed pivot door screen to all showers
Shower Outlet	Wall mounted shower on rail with chrome mixer
Towel Holder	Double towel rail holder or 2no. hooks (floorplan specific)
Handles	Finger pull cabinetry and doors to bathroom/ ensuite (where applicable)

Australian Made Kitchen	
Benchtops	20mm mineral surface benchtops
Doors/Drawers	Laminate panels and doors
Overhead Cupboards	Overhead cupboards above kitchen including feature open shelf
Sink	Stainless steel sink with chrome mixer
Handles	Finger pull cabinetry and doors to kitchen (where applicable)

Solar	
Solar PV	Minimum 2kw solar PV system with inverter (size to be determined at build stage)

Appliances	
Oven	600mm Fisher & Paykel black built-in oven
Cooktop	600mm Fisher & Paykel black induction cooktop
Rangehood	Fisher & Paykel stainless steel undermount rangehood
Dishwasher	600mm Fisher & Paykel stainless steel dishwasher

Laundry	
Trough	Freestanding laundry trough with cabinet and chrome mixer

Flooring	
Flooring	Timber laminate (please refer to standard floorplan for locations)
Floor Tiles	Ceramic floor tiles to bathroom, toilet, ensuite and laundry
Carpet	Carpet to remainder (refer to standard plans)

Wall Tiles	
Kitchen	Ceramic wall tiles to above kitchen bench including behind feature shelving
Shower	Ceramic wall tiles to shower walls
Bath	Ceramic wall tiles bath edge to floor

Paint	
Ceiling	Premium 2 coat ceiling paint system
Internal Walls	Premium 3 coat wall paint system
Timberwork	High gloss enamel to all interior wood work and doors
Cladding	2 coats to all exterior claddings

External	
Driveway	Concrete driveway (as per plan)
Landscaping	Full front and rear landscaping with plants, pebbles and mulch
Fencing	Fixed fencing to all boundaries to developers requirements (refer to plans)
Letterbox	Pre-formed letterbox
Clothesline	Folding clothesline (plan specific)
	(All external works to builders discretion)

Please note Nostra Homes and Developments Pty Ltd standard specifications are subject to change without notice and we reserve the right to substitute any items with equivalent products at anytime. Please note that various items that may be displayed in our homes may not be included in our standard specifications.

V10 AUGUST 2025



Designer basins & tapware

Full floating laminate cabinets

20mm mineral surface benchtop

Oversized floor tiles

Artist Impression: Images used are for colour reference and material finish only, please refer to contract drawings. Note: Render based on an Inverloch design.

Interior styling that is easily accessible.

Your choice of four colour schemes.



Mode.

A light and soothing sanctuary.



Luxe.

A moody and dramatic space.





UPGRADE OPTION

Coastal.

A calming retreat.



UPGRADE OPTION

Architecton.

Modern haven of luxurious contrast.





Built by Nostra Homes,
backed by trusted
partnerships.



BUILDER

Specialising in turn-key townhome living, Nostra Homes have been building homes across Melbourne since 2006. Nostra Homes maintains a focus on creating affordable homes using only quality products.

With a high level of standard finishes, Nostra Homes' Townhome options are a great choice for anyone looking for a modern, low maintenance living space with architectural appeal.

Nostra Homes' point of difference.

Distinguished architectural designs and craftsmanship.

- 

Architecturally designed turnkey homes
- 

Bespoke colour schemes
- 

Dedicated Customer Service Officer
- 

Energy Efficient
- 

12 Months RACV Home Assist*
- 

All Electric homes
- 25

25 Year Structural Guarantee*



DEVELOPER

Proudly developed by Sunbury's Millett Family, Rosenthal Place is the result of a long-standing local legacy that began in 1918. Originally a successful dairy farm and later an award-winning winery, the land has always played a meaningful role in the region's story.

has grown into one of Sunbury's most established and admired neighbourhoods. Over a decade in the making, this masterplanned estate offers the perfect balance of contemporary living and natural charm - where wide open spaces, rolling views and a strong sense of community create the lifestyle you've been searching for.

Guided by Tom Millett's vision to create an inclusive, family-focused community, Rosenthal

Our trusted suppliers.

Quality homes and strong partnerships, delivering excellence together.



NOTE All colours shown in this book are a guide only. Categories and colours are indicative and can be subject to change.
*For terms and conditions, please visit <https://nostrahomes.com.au/terms.html>

Build with property
experts you can trust.

Proudly built and developed by

NOSTRA
HOMES



House and land sold separately. Nostra Homes and Developments Pty Ltd acts as the builder of the home only. Buyers must enter into a separate contract with the land developer for the purchase and development of the land. Buyers should review the land and building contracts carefully, make their own inquiries and obtain independent advice before proceeding. Illustrations and information are intended to be indicative only and are believed to be correct at the time of publication. Nostra Homes and Developments Pty Ltd reserves the right to withdraw or alter any package at any time without notice at its absolute discretion. Estimated costs for the package are indicative only and other costs and fees are payable, including but not limited to: transfer/stamp duty, settlement/registration fees, legal/conveyancing fees, finance costs, site works, engagement of any consultants, approvals, connection for services and variations. All imagery on this brochure is for illustrative purposes only. Artist impression is for illustrative purposes only. Items depicted in these images that are excluded from the standard inclusions are included but not limited to pendant lighting, frameless shower screen and fixtures. Final drawings are subject to developer and council approval; refer to the contract documentation for further details. Nostra Homes reserves the right to amend specification and price without notice. The First Home Owners Grant is a Government incentive and is subject to change. Nostra Homes and Developments Pty Ltd, Information and other content contained within this document is believed to be accurate as at August 2025 but may change at any time without notice. No warranty or representation (implied or express) is given as to the accuracy, reliability or completeness of the information or other content contained in this document. CDB-U 48474