

NOSTRA
HOMES

TOWNHOMES

Redefine the way you live
in Evergreen, Clyde

RELEASE 2



 Stockland | Evergreen

Discover the charm of townhome living in Evergreen.

The next-generation of contemporary homes in Clyde aim to redefine the way you live, setting a new benchmark in flexible, light-filled and low maintenance living spaces.

As part of this vision, Nostra Homes has partnered with Stockland to bring you a selection of stunning 3 and 4 bedroom turn-key homes that provide a contemporary living solution for first home buyers, downsizers or someone looking for a low maintenance, modern lifestyle.

Featuring an attractive list of fixed price inclusions along with a modern and architecturally designed street appeal, these homes are the perfect choice.

“

The Nostra Homes team and I are dedicated and driven to deliver a premium level of service at every step of your Nostra Homes journey”



Anthony Caruana
Founder



Turn your dreams into reality.

Living at Evergreen, you can have it all – now and into the future. Everything you need for a lifestyle like no other is right here. Excellent transport connections, quality schools, shops and facilities empower you to create the life you want. And that's just the beginning. Evergreen is an evolving community, set to welcome plenty of new amenities to make everyday life even more convenient and relaxed.



8 mins
to shopping on Clyde



11 mins
Cranbourne train station



Parks
upcoming future parks



Primary
schools upcoming and existing,
close in proximity



Secondary
schools upcoming and existing
close in proximity



Go where the grass really is greener.

Located close to everything you need – schools, shops, amenities and transport, this is where you and your family will thrive.

With such a great list of nearby amenities along with a functional floorplan and architectural façade, you'll love calling Evergreen home.



Siteplan.



Illustrations are indicative and should be used as a guide only.
Siting is not to scale and may differ to final built forms.

Choose your design.



We provide you with the freedom to choose between a 3 or 4 bedroom design to find the perfect home that aligns with your lifestyle and budget.

Lot 2363	Lot 2364	Lot 2365	Lot 2366	Lot 2367	Lot 2368	Lot 2369	Lot 2370	Lot 2371
20.73sq	14.58sq	14.61sq	14.58sq	19.73sq	19.73sq	14.61sq	14.58sq	20.73sq
3-4 2 2	3 2 1	3 2 1	3 2 1	3-4 2 2	3-4 2 2	3 2 1	3 2 1	3-4 2 2
<input type="radio"/>	<input type="radio"/>	<input type="radio"/>	<input type="radio"/>	<input type="radio"/>	<input type="radio"/>	<input type="radio"/>	<input type="radio"/>	<input type="radio"/>



Lipari 19c

Lot 2363, 2371
House Size 20.73sq

  
 4 2 2

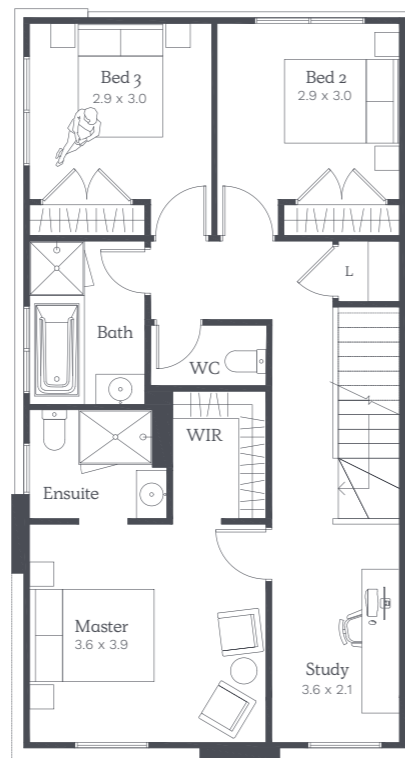
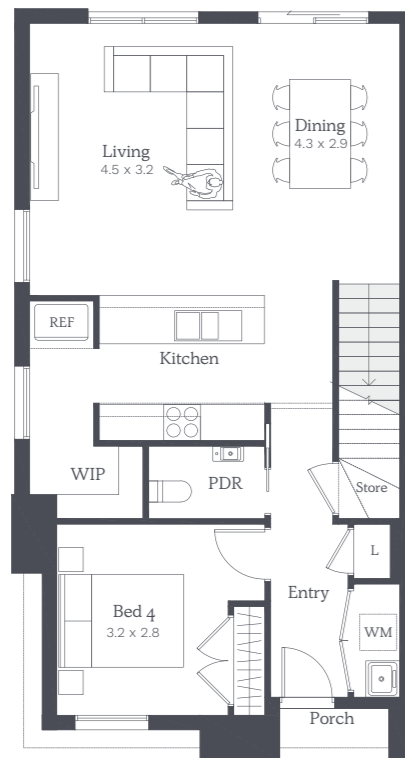
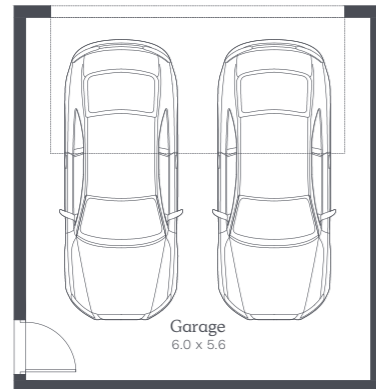

Images, floorplans and measurements are for illustrative purposes only. Plans are not to scale and may differ from final built forms. Your contract of sales will set out all binding terms and property information. Any changes to the floorplan with incur an additions cost. Refer to contract drawings for final floorplans and landscaping plans.

Lipari 14

Lot 2364-2366, 2369-2370
House Size 14.58sq

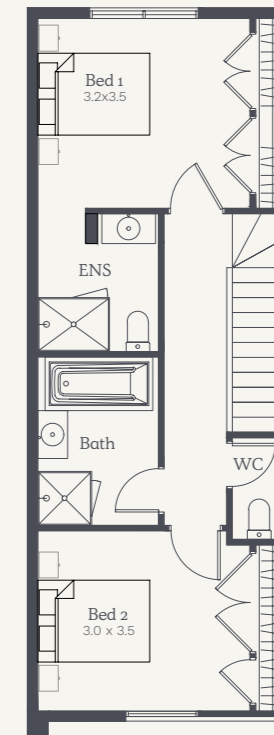
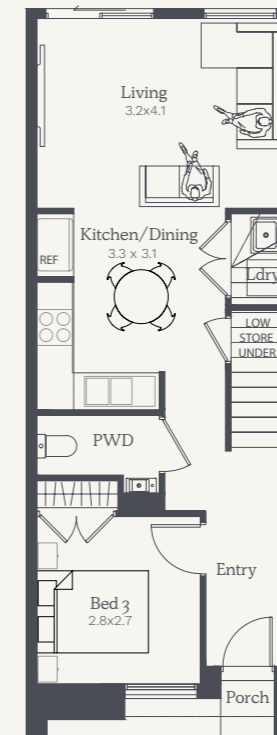
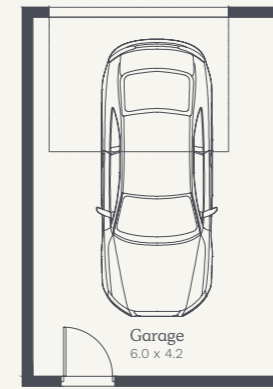

  
 3 2 1



Images, floorplans and measurements are for illustrative purposes only. Plans are not to scale and may differ from final built forms. Your contract of sales will set out all binding terms and property information. Any changes to the floorplan with incur an additions cost. Refer to contract drawings for final floorplans and landscaping plans.

Lipari 19

Lot 2367-2368
House Size 19.73sq

		
4	2	2

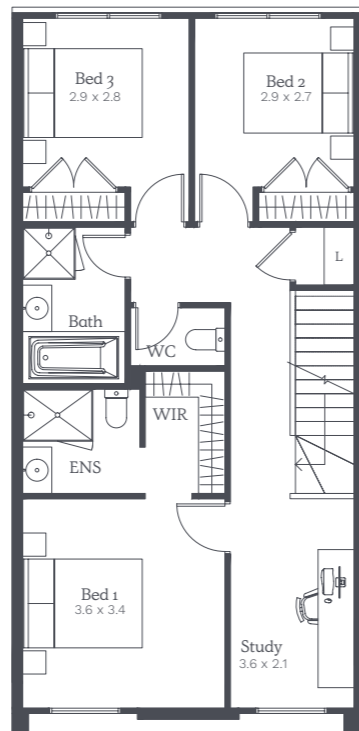
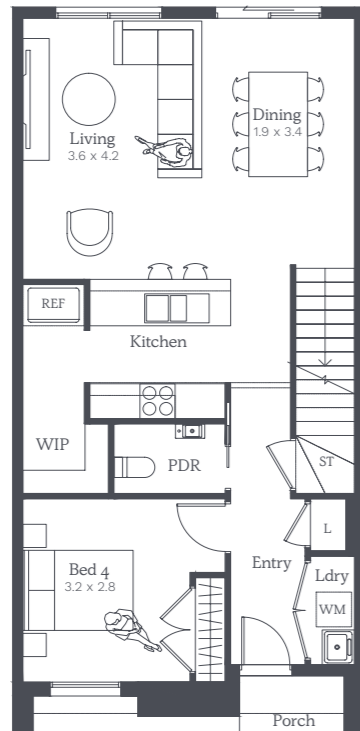
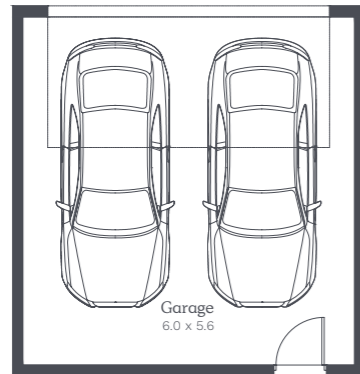

Images, floorplans and measurements are for illustrative purposes only. Plans are not to scale and may differ from final built forms. Your contract of sales will set out all binding terms and property information. Any changes to the floorplan will incur an additions cost. Refer to contract drawings for final floorplans and landscaping plans.



Discover how
good life is at
Evergreen.



 Stockland
Evergreen

Artist Impression. Subject to change.

Inclusions

General	
Guarantee	25 year structural guarantee
Construction	Dwelling constructed independently

Connections	
Taps	Garden Tap
Stormwater	Stormwater drains
Sewer	Sewer drains
Utilities	Electricity, gas and water connections
Fibre Optic	Fibre Optic provisions (does not include installation of Hub or final connections)
Costs	All connections exclude consumer connection fees and utility account opening fees

Foundations	
Site Costs	Fixed site costs (Includes rock and retaining walls) Note: Retaining walls are included for structural requirements only. Any retaining wall requirements for landscaping are not included.
Slab	Engineered concrete slab

Framing	
Wall Frames	Stabilised pine or steel wall frames with lintels and beams
Ceiling	Engineered designed roof trusses

Ceilings	
Single Storey	2740mm high ceilings
Double Storey	2590mm high ceilings to ground floor and 2440mm to upper levels
Plasterwork	Cove cornice to entire home

Windows	
Material	Aluminium windows
Locks	Keyed locks to all windows

Facade	
Facade	Facade as noted in approved architectural drawings

External Cladding	
Cladding	VBA compliant cladding

Roof	
Roof Pitch Materials	Metal sheet roofing or concrete roof tiles (floorplan specific)
	Fascia, gutter, downpipes and cappings

Insulation	
Wrap	Sisalation wall wrap
External Walls	Wall batts to external walls
Ceiling Cavity	Insulation wool to ceiling cavity of living areas
Gas Hot Water System	Gas solar hot water unit (note: when an estate requires recycled water connection, a gas continuous flow hot water unit will be supplied)

Garage	
Garage Door	Panel lift Garage door with 2 hand held and 1 wall mounted remote control

Staircase	
Stairs	MDF treads and risers with carpet (plan specific)

Doors/Furniture	
Entry	Solid core door with digital entrance lock
Internal	Flush panel doors with satin chrome passage handles and air cushioned door stops
Robes	Chrome knob to robe cupboards

Skirting/ Architraves	
Mouldings	67mm x 18mm Primed MDF skirting and architraves
Wet Area	Tiled Skirting 100mm to wet areas

Shelving	
Robes	x 1 melamine shelf with chrome hanging rails
Linen	x 3 melamine shelves
Pantry	x 4 melamine shelves

Electrical	
Safety Switches	Safety switches (residual current devices)
Smoke Detector(s)	Direct wired smoke detectors
Internal Light Points	LED downlights to home (as per plan)
External Lights	1 x Rear flood light
Exhaust Fans	Exhaust fans to areas with no openable window
Power Points	1 x Double powerpoint to each room (refer to Electrical Plans)
TV/Phone Point	1 x Television and phone point (refer to Electrical Plans)

Heating	
Heating Panels (Flat Roof)	Heating panels to all bedrooms and living
	Gas ducted heating with thermostat (number of points and unit size are floorplan specific) Note: Subject to gas availability. If no gas is available, heating panels will be provided.
Ducted Heating (Pitched Roof)	



Toilets

Toilet Suite	Dual flush cisterns with Vitreous China pan
Toilet Roll	Toilet roll holders
Basin	Wall mounted basin with mirror to powder room (plan specific)

Bathroom and Ensuite

Cabinetry	Laminate cabinets
Benchtops	20mm mineral surface benchtops
Basin/Tapware	Vitreous china designer basins with chrome flick mixers
Bath	White acrylic bath with chrome outlet and tap set (floorplan specific)
Mirror	Polished edge mirrors (size is width of vanities)
Shower Base	Pre-formed shower base to all showers (refer to plans for size)
Shower Screen	Framed pivot door screen to all showers
Shower Outlet	Wall mounted shower on rail with chrome mixer
Towel Holder	Double towel rail holder or 2no. hooks (plan specific)
Handles	Designer pull handles (where applicable)

Australian Made Kitchen

Benchtops	20mm mineral surface to benchtops
Doors/Drawers	Laminate panels and doors
Overhead Cupboards	Overhead cupboards above kitchen including feature open shelf
Sink	Stainless steel sink with chrome mixer
Handles	Designer pull handles (where applicable)

Appliances

Oven	Bellissimo 600mm built-in oven
Cooktop	Bellissimo 600mm gas cooktop
Rangehood	Technika undermount rangehood
Dishwasher	600mm stainless steel dishwasher

Laundry

Trough	Freestanding laundry trough with cabinet and chrome mixer
---------------	---

Flooring

Flooring	Timber laminate (please refer to standard floorplan for locations)
Floor Tiles	Ceramic floor tiles to bathroom, toilet, ensuite and laundry
Carpet	Carpet to remainder (refer to standard plans)

Wall Tiles

Kitchen	Ceramic wall tiles to above kitchen bench including behind feature shelving
Shower	Ceramic wall tiles to shower walls
Bath	Ceramic wall tiles bath edge to floor and above bathtub

Paint

Ceiling	Premium 2 coat wall & 2 coat ceiling paint system
Timberwork	High gloss enamel to all interior wood work and doors
Cladding	2 coats to all exterior claddings

External

Driveway	Concrete driveway (as per plan)
Landscaping	Full front and rear landscaping with plants, pebbles and mulch
Fencing	Fixed fencing to all boundaries to developers requirements (refer to plans)
Letterbox	Pre-formed letterbox
Clothesline	Folding clothesline (plan specific)

(All external works to builders discretion)

Please note

Nostra Homes and Developments Pty Ltd standard specifications are subject to change without notice and we reserve the right to substitute any items with equivalent products at anytime. Please note that various items that may be displayed in our homes may not be included in our standard specifications. Where the estate or development has no gas supplied, electric will be provided at no cost.

V2 27.08.2024



Designer basins & tapware

20mm Mineral Surface benchtop

Full floating laminate cabinets

Oversized floor tiles

Artist Impression. Mode Colour Scheme depicted.
Note: Image shown includes upgrades including: Freestanding bath, pill shaped mirror with LED, floor to ceiling tiles, black tapware & square set cornices
Render based on a Inverloch Series bathroom design.

Interior styling that is easily accessible.

Your choice of three colour schemes.



Mode.
A light and soothing sanctuary.

A collection of material swatches for the 'Mode' scheme. It includes various shades of wood, a grey fabric swatch, and several white and light grey paint swatches. A small wooden bowl with a spoon and a white ceramic dish with a fork are also included.

Luxe.
A moody and dramatic space.

A collection of material swatches for the 'Luxe' scheme. It features a dark wood swatch, a dark grey fabric swatch, and several white and light grey paint swatches. A small wooden bowl with a spoon, a white ceramic dish with a fork, and a string of light-colored beads are also included.



Coastal.

A calming retreat.



Nostra Homes' point of difference.

Motivated to deliver architecturally inspired design and craftsmanship.



Architecturally inspired homes



Dedicated Customer Service Officer



12 Months RACV Home Assist*

25

25 Year Structural Guarantee*



Carefully curated colour schemes



Trusted suppliers and construction method



Energy Efficient

NOTE All colours shown in this book are a guide only. Categories and colours are indicative and can be subject to change.

*For terms and conditions, please visit <https://nostrahomes.com.au/terms.html>

A strong partnership, delivering excellence together.

NOSTRA
H O M E S

BUILDER

Specialising in turn-key townhome living, Nostra Homes have been building homes across Melbourne since 2006. Nostra Homes maintains a focus on creating affordable homes using only quality products. With a high level of standard finishes, Nostra Homes' Townhome options are a great choice for anyone looking for a modern, low maintenance living space with architectural appeal.

 **Stockland**

DEVELOPER

For more than 70 years, Stockland have been creating and curating communities with people at the heart of the places they create. As one of Australia's largest diversified property groups, they are building on their legacy, helping more Australians achieve the dream of home ownership and creating places and spaces full of energy, soul and life – from residential and land lease communities through to retail town centres, workplaces and logistics assets. Their purpose – a better way to live – is central to everything they do.

We're here to guide you on your journey to home ownership.



Shannon Playnsek
Townhome Sales Consultant

0484 144 981
shannonp@nostrahomes.com.au

Build with property experts you can trust.

Proudly built and developed by

NOSTRA
H O M E S

 **Stockland**

Disclaimer: House and land sold separately. Nostra Homes and Developments Pty Ltd acts as the builder of the home only. Buyers must enter into a separate contract with the land developer for the purchase and development of the land. Buyers should review the land and building contracts carefully, make their own inquiries and obtain independent advice before proceeding. Illustrations and information are intended to be indicative only and are believed to be correct at the time of publication. Nostra Homes and Developments Pty Ltd reserves the right to withdraw or alter any package at any time without notice at its absolute discretion. Estimated costs for the package are indicative only and other costs and fees are payable, including but not limited to: transfer/stamp duty, settlement/registration fees, legal/conveyancing fees, finance costs, site works, engagement of any consultants, approvals, connection for services and variations. All imagery on this brochure is for illustrative purposes only. Artist impression is for illustrative purposes only. Items depicted in these images that are excluded from the standard inclusions are included but not limited to pendant lighting, frameless shower screen, freestanding bath, finger-pull cabinetry and fixtures. Final drawings are subject to developer and council approval; refer to the contract documentation for further details. Nostra Homes reserves the right to amend specification and price without notice. The First Home Owners Grant is a Government incentive and is subject to change. Nostra Homes and Developments Pty Ltd. Information and other content contained within this document is believed to be accurate as at October 2024 but may change at any time without notice. No warranty or representation (implied or express) is given as to the accuracy, reliability or completeness of the information or other content contained in this document.